

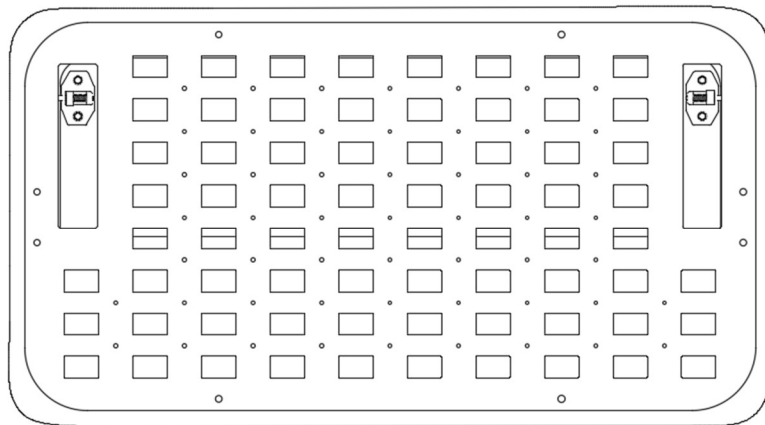

Installation guide Mollesystem R65



Required materials:

- Drill 4.2 mm
- Tap M5
- Nutkey nr. 8
- Screwdriver (phillips head / PH2)
- Paint brush and oil

Materials supplied:

- M5*25 screws (8x)
- Washer (8x)
- Cover cap (8x)

We strongly recommend that you read the manual in advance.

It is important that the Explore Glazing products are assembled correctly and safely. Careless assembly can lead to accidents and serious damage and / or injury to you or others. If you have no technical experience or are not familiar with the general assembly instructions, we recommend that you have our products assembled by a professional company.

If the Explore Glazing window has not yet been mounted in your car, we advise you to mount the Mollesystem plate on the window first.

1. On the inside of the window, we have already taken over the position for the Mollesystem; center points.

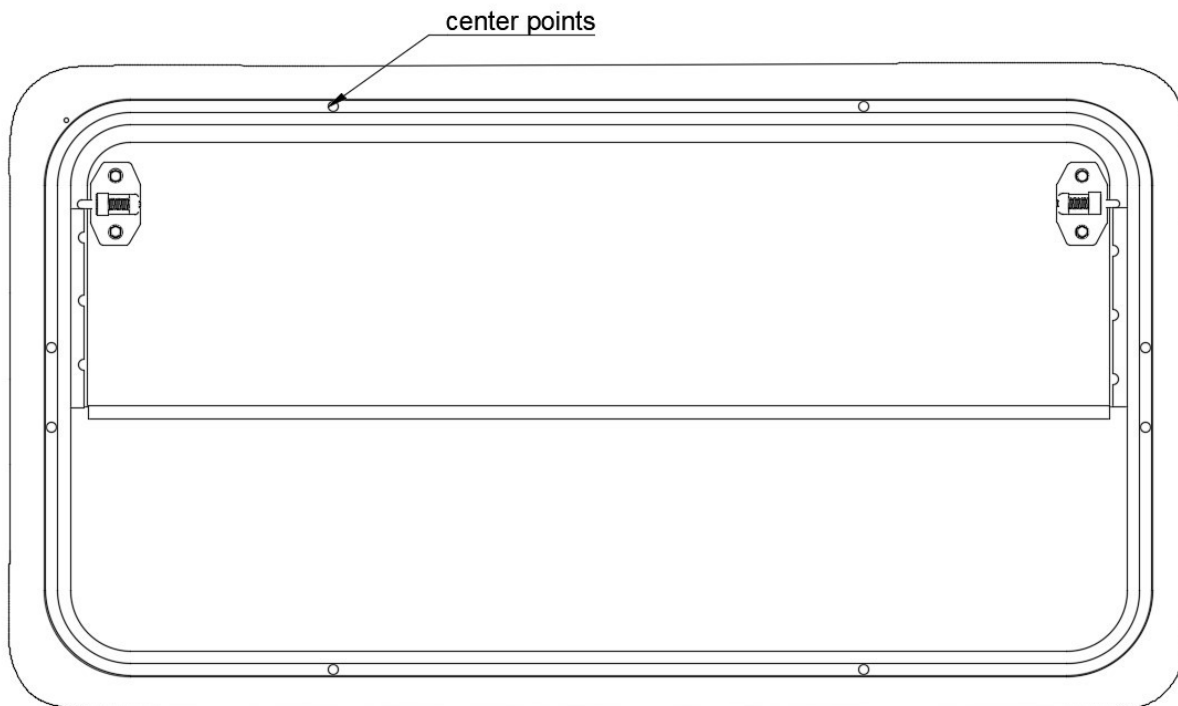

2. Drill the center points with a 4.2 mm drill; preferably with a column drilling machine. If you don't have these, make sure you drill the holes perpendicular. Use sufficient oil when drilling.

Note: you should not drill the holes completely through the frame, but only that part of the profile where the center points are positioned.

only drill this
profile!

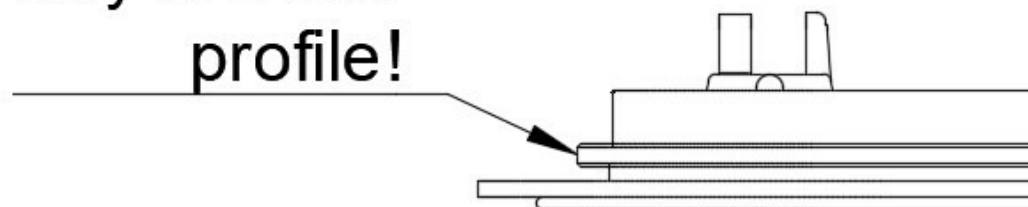

3. Tap the holes with an M5 machine tap. Use sufficient oil during tapping.

4. Clean the window carefully to avoid damaging the powder coating.
5. Place the cap washers (8x) and mount the Mollesystem with the M5x25 screws by tightening them a few turns.

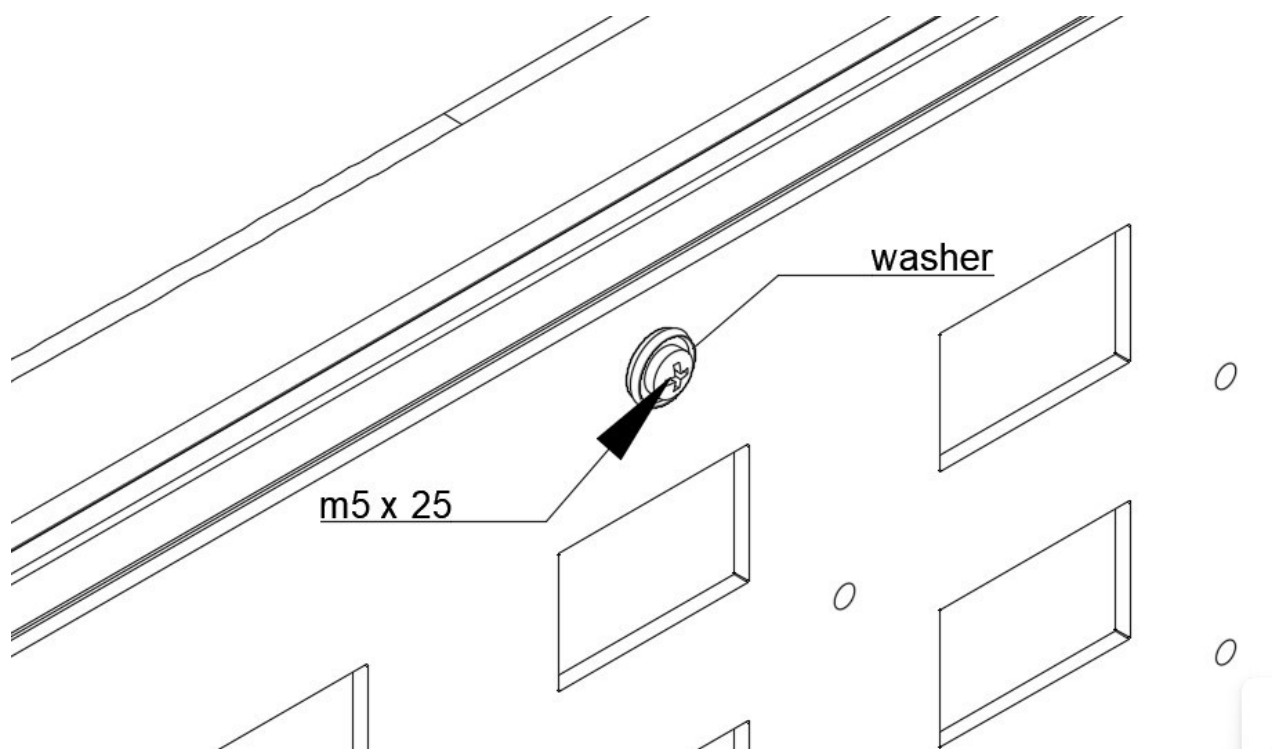

6. After all bolts have been mounted, the bolts should be evenly tightened by hand.
7. Then place the cover caps (8x).

